

**12x8x16 Split Face Block**

**Product No: 123000100**

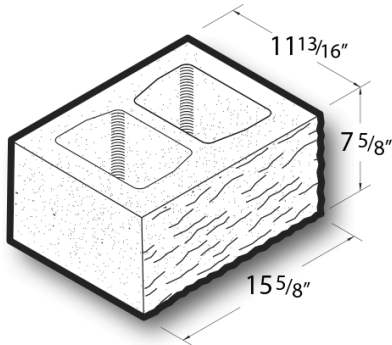

12x8x16 Split Face Block is architectural CMU that has the appearance of hand-chiseling to give wall designs a highly textured look. [Contact](#) your Best Block representative for special requests and additional options.

- Available in medium, normal, and light-weight varieties
- Competitively priced and produced locally.
- Concrete blocks are naturally fire-resistant, highly durable, and its mass creates energy-efficient wall systems.
- Item weight and pallet count may vary by location.
- [Contact](#) your Best Block representative for more information.

**Unit(s)**

<b>Product No.</b>	123000100
<b>Weight/Block:</b>	53
<b>Block/Pallet:</b>	48
<b>Pallet Weight:</b>	2604

**Available Colors**





#725 Smoke



#8 Charcoal



#813 Limestone  
Buff



#9 Cream

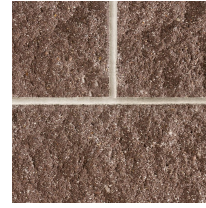

Cocoa



Georgetown  
White

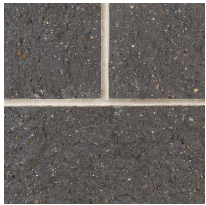

Gun Barrel



Midnight



Palomino



Paprika



Sandstone



Terra Cotta



Walnut Brown



Wet Stone