

**Versa-Lok™ Square Foot Unit**

**Product No: 123045000**

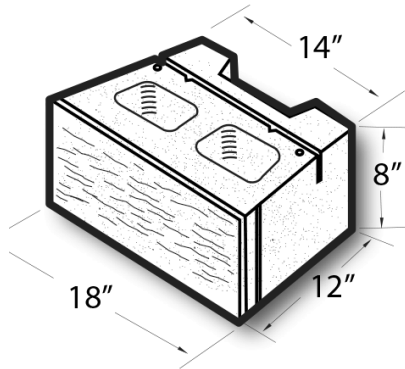

Versa-Lok™ Square Foot Unit are designed to fulfill the needs of any landscape project, from both an aesthetic and a functional standpoint. Segmental retaining wall blocks are available in a wide variety of colors, sizes, and textures to create straight or curved lines, steps, and corners. [Contact](#) your Best Block representative for special requests and additional options.

- Available in medium, normal, and light-weight varieties
- Competitively priced and produced locally.
- Concrete blocks are naturally fire-resistant, highly durable, and its mass creates energy-efficient wall systems.
- Item weight and pallet count may vary by location.
- [Contact](#) your Best Block representative for more information.

**Unit(s)**

<b>Product No.</b>	123045000
<b>Weight/Block:</b>	83
<b>Block/Pallet:</b>	32
<b>Pallet Weight:</b>	2716